

HERYTAGE

User and Installation Manual

For H02KVA thru H20KVA Model UPS



IMPORTANT SAFETY INSTRUCTIONS, SAVE THESE INSTRUCTIONS

- This Manual contains important instructions for models 2kVA through 20kVA that should be followed during installation and maintenance of the UPS and Batteries.

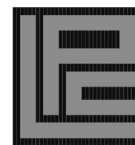
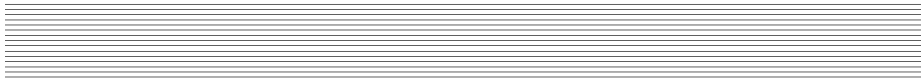

LEGACY
POWER CONVERSION

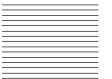

The Best Power Protection in the Business™

Contents

	Page
Safety Warnings.....	3
Symbols.....	3
Introduction.....	4
General Description.....	4
Specifications.....	5

Section

100	Receiving your Herytage UPS.....	7
101	Unpacking and inspection.....	7
102	Storage.....	7
200	Installation Guidelines.....	8
201	Installation Considerations.....	8
202	Location.....	8
203	Remote battery installation.....	9
204	Customer supplied batteries with Legacy cabinets.....	9
205	Dimensions and clearance requirements.....	9
206	External bypass switch dimensions.....	10
207	External battery cabinet dimensions.....	10
300	Wiring Instructions.....	11
301	Softwired Installations.....	11
	Table 301-1 Minimum circuit breaker requirements.....	12
302	Hardwired Installations.....	13
	302-1 External bypass switch Installations	13
	Figure 302-1A Hard-wired Installation Overview.....	14
	Figure 302-1B Bypass switch Terminal Block.....	14
	302-2 Minimum input over-current protection.....	15
	Table 302-1 Minimum circuit breaker requirements.....	15
	302-3 Installation Wiring Connection Diagrams.....	15
	Figure 1 <i>Wiring connection diagram/120 Input with External bypass</i>	16
	Figure 2 <i>Wiring connection diagram/208-240 Input with External bypass</i>	17
	Figure 3 <i>Wiring connection diagram/208 Input with MBB External bypass</i>	18
303	Battery installation and connection.....	19
304	Bypass switch wiring / Phase check.....	20
305	User interface wiring connections.....	22
	Table 305-1 <i>DB 9 Serial communications pin outs</i>	23
	Table 305-2 <i>User interface wiring connection block</i>	23

400	System operation.....	24
401	Startup	24
	401-1 Softwired units (Line cord and receptacles).....	24
	401-2 Hardwired units.....	25
402	Shutdown of the Herytage UPS	26
	402-1 Softwired systems.....	26
	402-2 Hardwired units.....	26
500	System Features.....	27
501	On / Off Switch.....	27
	501-1 Herytage UPS On / Off Switch Positions.....	27
502	Bypass switch / AC disconnect operation.....	27
	502-1 AC disconnect switch.....	27
	502-2 Bypass switch.....	28
503	Display Panel / LED lights.....	29
	503-1 Bar Graph LEDs.....	29
	503-2 Single LEDs.....	29
504	Keypad / LCD display.....	30
	504-1 System Status/System Modes.....	30
	504-2 Passwords.....	30
	504-3 Keypad Functions and Programming.....	31
505	Parameter Table.....	32
600	RS 232 Serial communications.....	37
601	DB9 Serial Terminal / Computer hook up	37
602	System Status/System Modes.....	37
603	Passwords.....	38
604	RS232 Commands.....	38
605	Modem Hook Up (optional)	39
700	Alarms.....	40
701	Shutdown and latching alarms.....	40
702	Alarm Table	40
703	Alarm Mask.....	42
800	Battery removal / replacement.....	43
801	Battery safety / cautions.....	43
	Warranty.....	44
	Warranty registration form.....	46

SAFETY WARNINGS

IMPORTANT SAFETY INSTRUCTIONS – SAVE THESE INSTRUCTIONS

**This manual is for Herytage UPS:
Horizontal Chassis 2kVA through 20kVA**

DANGER: UPS contain HAZARDOUS VOLTAGES. Because of these voltages, installation of the system should be performed by a qualified electrician. The electrician must install according to local and national electrical codes.

There are NO USER SERVICEABLE PARTS inside the UPS, repairs of the system should be performed by qualified service personnel.

CAUTION: Batteries can present a risk of electrical shock or burn from high short circuit current. Observe proper precautions.

CAUTION: Proper disposal of batteries is required. Refer to your local codes for disposal requirements.

CAUTION: A UPS contains its own energy source (batteries). Output voltage may be present even when the UPS is not connected to an AC supply.

CAUTION: Never dispose of batteries in a fire. Batteries may explode when exposed to flame.

CAUTION: Never open or mutilate batteries. Released electrolyte is harmful to the skin and eyes, and may be extremely toxic.

CAUTION: To reduce the risk of fire or electric shock, install this UPS in a temperature and humidity controlled, indoor environment, free of conductive contaminants. Ambient temperature must not exceed 40 C (104 F) without de-rating the maximum load. Do not operate near water or excessive humidity (95% max).

CAUTION: Do not remove or unplug the input cord when the UPS is turned on. This removes the safety ground from the UPS and the equipment connected to the UPS.

SYMBOLS: Listed below are the symbols utilized on the product labels or within the installation / user manual

 DC

 AC

 Ground

INTRODUCTION

Thank you for purchasing this quality product from Legacy Power Conversion, Inc.

Read this manual thoroughly before installing or operating your Herytage UPS system. Keep this manual for future reference.

This unit will provide highly regulated and controlled power for your sensitive electronics equipment, protecting it from frequent power glitches that are inherent in commercial power.

IF YOU HAVE ANY QUESTIONS OR PROBLEMS PLEASE LET US HELP... Legacy Power Conversion, Inc is committed to outstanding customer service. Our customer service center will be happy to help you with any problems or questions you may have. Service technicians are available 24 hours a day, 365 days a year. Just call the telephone number below, or send a fax to the service fax number. Please have your unit's serial number available.

TELEPHONE NUMBER - 800-859-5711 or 608-565-5878

FAX NUMBER - 608-565-5879

Email – service @ lpc-ups.com

GENERAL DESCRIPTION

The Herytage UPS is an Electronically Controlled Ferroresonant Transformer based UPS system designed to provide transient free, regulated power to your load equipment. Features that differentiate the Herytage UPS are:

- Electronically controlled Ferroresonant Transformer
- State of the art user interface
- Keypad with a back lit LCD display, rear access RS232 communications interface port.
- Detailed power quality, control, and unit metering information are all easily accessible.
- Last 248 power quality and alarm events logged by time, date, including start and stop time.
- Dial in modem option.

Specifications*

Model		2kVA 1.6kW	3kVA 2.4kW	4kVA 3.2 kW	6kVA 4.8kW	8kVA 6.4kW	10kVA 8kW	16kVA 12.8kW	20kVA 16kW
AC Input									
Input ACV & circuit breaker requirements – standard hardwire connection	120VAC	30A	30A	50A	60A	-	-	-	-
	208VAC	15A	20A	30A	40A	60A	70A	100A	125A
	240VAC	15A	15A	30A	40A	50A	60A	90A	110A
Line Cord¹ (optional)	120VAC	C ² , I ² , J, E	J, E	E	-	-	-	-	-
	208VAC	O, K, L	K, L	L, M	N, P	-	-	-	-
	240VAC	O, K, L	O, K, L	L, M	N, P	-	-	-	-
Input Voltage Window	+15%, -20% of nominal VAC Input @ full load +15%, -40% of nominal VAC Input @ 50% load								
Frequency	60Hz, ± 3Hz. Adjustable window								
AC Output									
Output ACV – Hardwire	120 / 208 / 240								
Output Receptacles	Optional								
Output waveform	Computer grade sine wave output power								
Regulation	± 3% voltage regulation								
Load Compatible	Guaranteed compatible with all loads for 90 days from date of purchase								
Overload	150% surge capability, overload alarm 101% load to 125% load for 10 min. before shutdown. Greater than 125% the system will shutdown in 5 seconds.								
Unit									
Dimensions H x W x D (in.)	25.2 x 16.2 x 23 ³			37.5 x 17.75 x 33.25			39 x 22 x 34		
Weight (lbs.)	208 ³	275 ³	290 ³	565 ³	465	530	570	665	
Efficiency	87%	88%	90%	91%	93%	93%	91%	91%	
Heat Loss BTU / W	816/239	1116/327	1213/355	1619/475	1645/482	2055/602	2160/632	3238/95	
Noise Attenuation	120db common mode, 60db transverse (normal) mode								
Isolation	Output is completely isolated from commercial power with less than 2 pf effective capacitive coupling primary to secondary. Secondary has neutral to ground bond, qualifying as a separately derived power source								
Surge Protection	6000 volts are suppressed to safe levels per ANSI/IEEE C62.41 – 1997 category A & B waveforms								
Operating Temperature	0° to 40° C (32° to 104° F)								
Relative Humidity	0 to 95% without condensation								
High altitude operation	Max. altitude 10,000 ft – de-rate 1° C off max operating temp. per 1000 ft. above sea level								
Agency	UL 1778, cUL listed								
User Interface	Keypad w/ LCD display, RS232 serial communications, dial in modem								

* Specifications may change without notice.

¹ Line Cord Designators: C = 5-20P, I = L5-20P, J = L5-30P, E = 5-50P, O = 6-15P, K = L6-20P, L = L6-30P, M = L14-30P, N = 6-50P, P = L6-50P

² 20 Amp Line Cord limits battery charger current to 4 Amps.

³ Weight and Dimensions are for UPS with standard internal runtime.

Specifications* (continued)

Model	2kVA 1.6kW	3kVA 2.4kW	4kVA 3.2 kW	6kVA 4.8kW	8kVA 6.4kW	10kVA 8kW	16kVA 12.8kW	20kVA 16kW
DC & Inverter								
Nominal DC voltage	48VDC			72VDC	96VDC	120VDC	96VDC	120VDC
DC Current	39	59	78	78	78	78	157	157
Charger Current	8A ²							
Runtime – (Std Battery) 100% Load 50% Load	11 min 32 min	18 min 47 min	11 min 32 min					
Overload	150% surge capability, overload alarm 101% load to 110% load for 10 min. before shutdown. Greater than 110% the system will shutdown in 5 seconds.							
Efficiency (on inverter)	85%							
Sound Level (Inverter)	50dBA	50dBA	52dBA	54dBA	55dBA	55dBA	53dBA	55dBA

* Specifications may change without notice.

² 20 Amp Line Cord limits battery charger current to 4 Amps.

100 Receiving your Herytage UPS

Caution: The Herytage UPS assemblies are very heavy, insure you are prepared to unload, unpack, and move these weights.

101 Unpacking and Inspection

Upon receiving shipment of your equipment, it is important to check items received against the packing slip. Check all pieces for shipping damage by unpacking and inspecting. If items are missing or damaged, call our customer service department. They can assist in filing a claim with the shipping carrier.

If installation requirements are not immediate, it is best to repack the system into its original packing material for storage.

102 Storage

Store Herytage UPS prior to use at temperatures between -20° and $+40^{\circ}$ Celsius (-4° to $+104^{\circ}$ Fahrenheit). Protect the system from moisture and weather.

If storing the Herytage UPS modules containing batteries, it is best to store them at temperatures less than 77° Fahrenheit. This allows the batteries to have a longer shelf life. If you plan to store them for more than 4 months it is important to unpack the system to recharge the batteries. Consult with the factory customer service department for assistance.

200 Installation Guidelines

Herytage UPS are intended to be installed in a temperature controlled, indoor area free of conductive contaminants.

See specifications for more details on the temperature range, environment, and altitude. In addition consider any national and local codes you may have to follow.

201 Installation considerations

Before installation of your new Herytage UPS, be sure to take into consideration the site you have selected. UPS systems produce heat and therefore require ventilation as well as accessibility.

Consider these factors:

- Input Source Voltage
- Available Single Phase KVA
- Bypass Switch
- Excessively Long Power Runs
- Distance to Critical Load
- Proper Ground Techniques
- Generator Applications
- Remote Emergency Power Off
- Ventilation
- Size of the UPS
- Weight of UPS and Batteries
- Room Temperature
- Audible noise
- Clearances
- Accessibility
- Communications

202 Location

When you plan the location of your UPS, remember to:

- Avoid temperature and humidity extremes
- Provide shelter from the elements (especially moisture)
- Place as near as possible to the computer or other critical loads
- Maintain 8 inches of clearance in back for ventilation, and a minimum of 36 inches in front for ventilation and maintenance. A larger clearance in front is helpful, but not required.

203 Remote battery installations

If the batteries are installed in a remote location (battery room) utilize DC circuit protection rated at 250A and 20,000A AIC rating. If the batteries must be some distance from the UPS you may need to install larger battery cables between the battery cabinets and the UPS. Call your customer service representative if you would intend to use anything other than standard cable lengths.

204 Customer Supplied batteries with Legacy battery cabinet(s)

Utilize the same number, size and type of battery as offered by Legacy Power Conversion, Inc.

Energys NP18-12BFR (Legacy Part Number BAT-0373)
C&D Technologies UPS 12 - 140 (Legacy Part number BBAT-0065)
Energys NP33-12 (Legacy Part number BBAT-0065)
C&D Technologies UPS 12 - 270 (Legacy Part number BBAT-0103)
C&D Technologies UPS 12 - 310 (Legacy Part number BBAT-0122)
C&D Technologies UPS12-150MR (Legacy Part number BBAT-10031)
C&D Technologies UPS12-300MR (Legacy Part number BBAT-10032)
C&D Technologies UPS12-350MR (Legacy Part number BBAT-10033)

205 Dimensions and clearance requirements

Table 1 Dimensions and Clearances

Model	Height (In.)	Width (In.)	Depth (In.)	Front Clearance (In.)	Back Clearance (In.)
2kVA ¹ 3kVA ¹ 4 kVA ¹	25.2	16.2	23	36	8
6 kVA 8 kVA 10 kVA	37.5	17.75	33.25	36	8
16 kVA 20 kVA	39	22	34	36	8

¹ Dimensions are for UPS with standard internal runtime.

206 External Bypass Switch

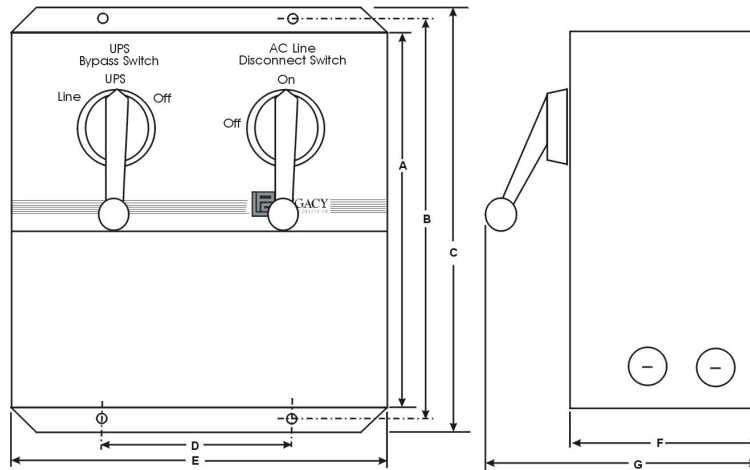

Dimension (in)	A	B	C	D	E	F	G	Weight
SW040xxxx	15.0	16.1	17.0	8.0	12.0	7.0	9.4	23
SW080xxxx	16.0	17.1	18.0	12.0	16.0	9.1	11.9	36
SW125xxxx	16.0	17.1	18.0	12.0	16.0	9.1	11.9	38

Allow 36" for service clearance in front of the bypass switch.

207 External Battery Cabinet

2 thru 4K battery cabinet dimensions

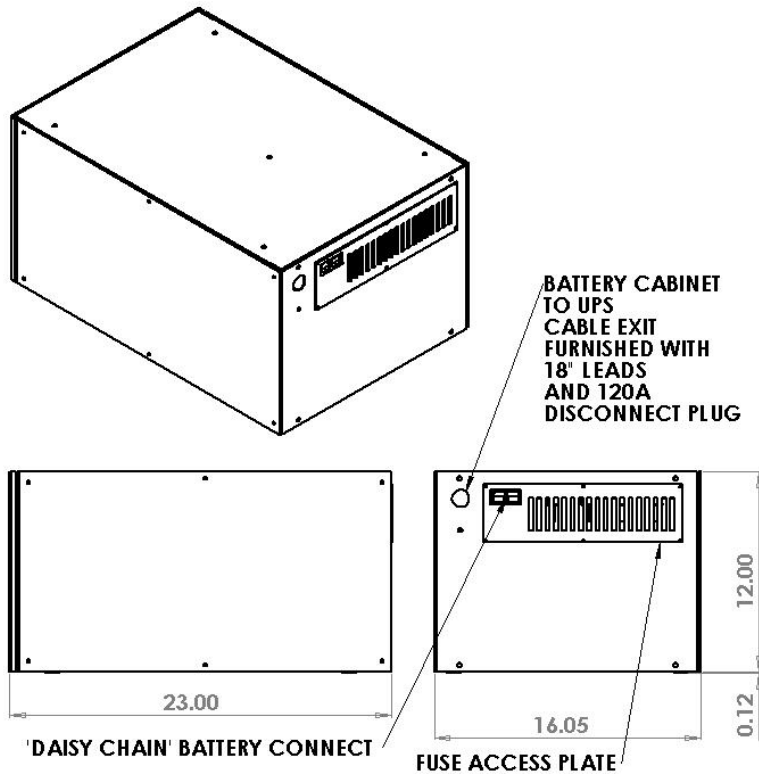

6 thru 20K battery cabinet dimensions

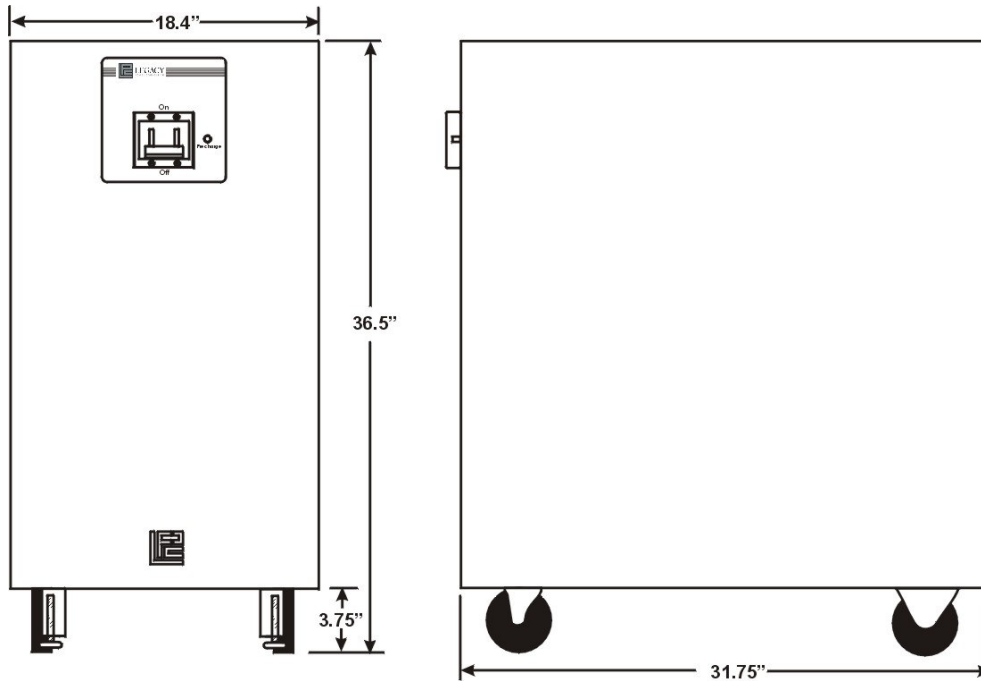

Allow 36" for service clearance in front and on one side of the battery cabinet. Placing cables in flexible metal conduit will allow for movement of battery cabinet for service.

300 Wiring Instructions

There are two basic installation configurations of the Herytage UPS system. Following is an overview of each configuration.

- Soft-wired (Line cord & receptacles)
- Hard-wired with external bypass switch

Installation of electrical wiring should be completed by a qualified electrician.

National electrical code and applicable local codes should be followed.

301 Soft-wired installation (Line-cord and receptacle)

Installation requires a proper wall receptacle for the Herytage UPS power cord to plug into, and installation of external bypass receptacles.

Note: External bypass receptacles provide power to your load equipment in the event that the Herytage UPS requires maintenance.

Proper breaker sizing for the input line cord receptacle depends on the input voltage / plug option ordered, see Table 301-1. Review the Herytage UPS input voltage on the

name plate – if it differs from the power you have available in your building call Legacy Power Conversion customer service.

Table 301-1 Circuit breaker minimum requirements (Soft-wired installations)

Model	Input Voltage	Line Cord Option ¹	Minimum Circuit Breaker Requirements
2kVA / 1.6kW	120	C, I	20A
	120	J, E	30A, 50A
	208	O, K, L	15A
	240	O, K, L	15A
3kVA / 2.4kW	120	J, E	30A
	208	K, L	20A
	240	O, K, L	15A
4kVA / 3.2kW	120	E	50A
	208	L, M	30A
	240	L, M	30A
6kVA / 4.8kW	120	NA	60A
	208	N, P	40A
	240	N, P	40A

¹ Line Cord Designators: C = 5-20P, I = L5-20P, J = L5-30P, E = 5-50P, O = 6-15P, K = L6-20P, L = L6-30P, M = L14-30P, N = 6-50P, P = L6-50P

Figure 301-1 - 2kVA - 6kVA soft-wired installation overview

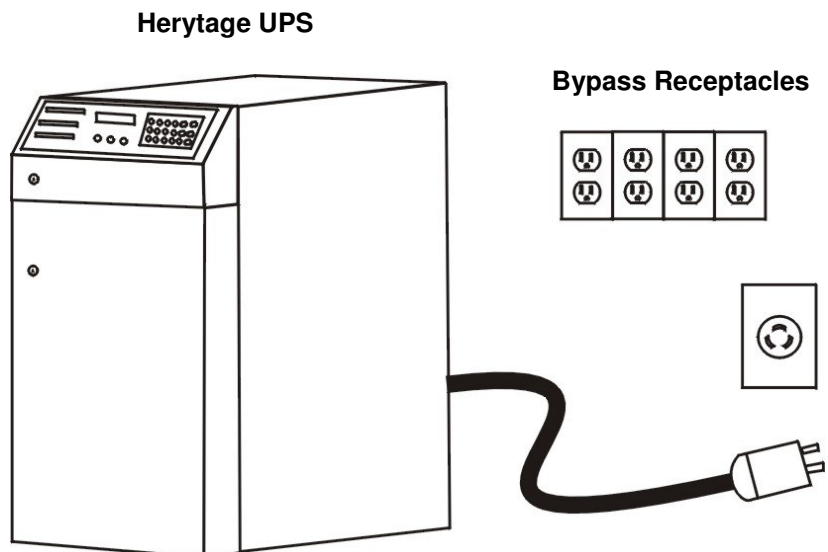

302 Hard-wired Installations

General requirements for hardwire Herytage UPS installations

- Input over-current protection and Output over-current protection and AC output disconnect switch for Herytage UPS must be provided by the installer. It should be installed and sized according to national and local electrical codes.
- External bypass switches should be installed within sight of Herytage UPS.
- Follow applicable national and local electrical codes when installing the grounding system. Herytage UPS grounding conductor should be at minimum the same size (ampacity) as circuit conductors.
- All circuit conductors including the neutral should be the same size (ampacity).
- Use isolated ground receptacles to obtain the best protection against electrical noise.
- A separate dedicated conduit system should be utilized for the Herytage UPS input and output wiring.
- Flexible conduit should be used to allow movement of the Herytage UPS to gain side service clearance.
- Load imbalance should not exceed 40% / 60%; 2-4K units do not have this restriction. 6K units L1-N 100% max., L2-N 50% max.

302-1 External bypass switch installations

The 2kVA through 20kVA Herytage UPS may be ordered with an external bypass switch. The external bypass switch is typically mounted on a wall within site of the Herytage UPS. See Figure 302-1A.

1. The wiring access panel for the external bypass switch is located on the front bottom half of the external bypass switch module, remove the screws securing the bottom half of the front cover to obtain access to the terminal blocks. See Figure 302-1B
2. Input and output wiring to and from the Herytage UPS and to and from the external bypass switch should be routed through separate conduits. Conduit connection points are located on the back of the UPS, the same conduit connection points are on the external bypass switch. Locate the pre-punched knockouts for starter holes.
3. Review input and output voltages on the unit data plate and insure they are proper for your installation, select wiring connection diagram figure 1 or 2 for appropriate connection. If the wrong input or output voltages were ordered – call Legacy Power Conversion customer service for assistance.

Figure 302-1A - Hard-wired Installation Overview

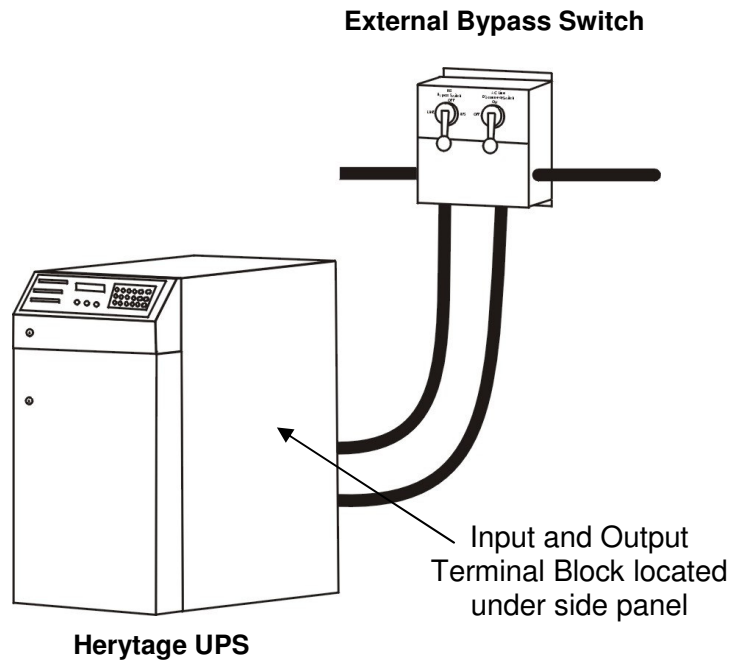
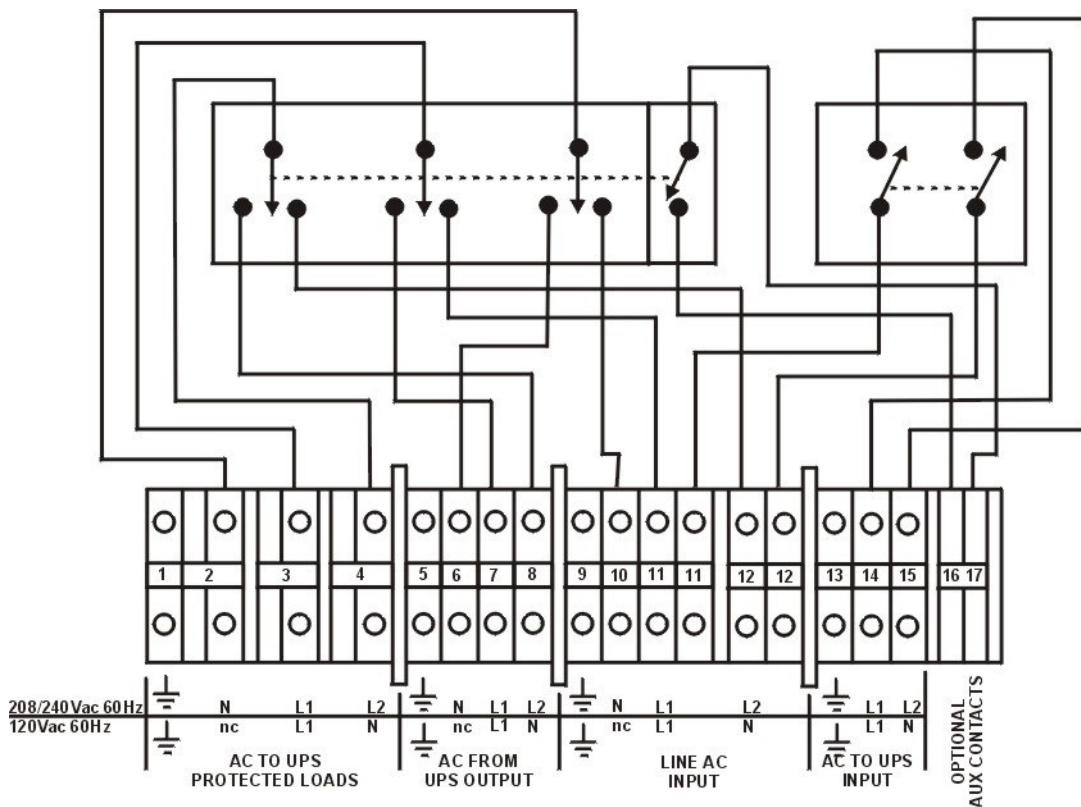

Figure 302-1B Bypass Switch Terminal Block



302-2 Minimum input over-current protection (Hardwired Installations)

Table 302-1 Minimum input circuit breaker and wire size requirements for hardwired installation

Unit Size	Input Voltage					
	120		208		240	
	Circuit Breaker	Wire Size	Circuit Breaker	Wire Size	Circuit Breaker	Wire Size
2kVA / 1.6kW	30A	12	15A	14	15A	14
3kVA / 2.4kW	30A	10	20A	12	20A	12
4kVA / 3.2kW	50A	8	30A	10	30A	10
6kVA / 4.8kW	60A	6	40A	8	40A	8
8kVA / 6.4kW	-	-	60A	6	50A	8
10kVA / 8kW	-	-	70A	4	60A	6
16kVA / 12.8kW	-	-	100A	2	90A	3
20kVA / 16kW	-	-	125A	1/0	110A	1

Use a minimum of 75°C rated wire. Consider all other applicable national or local electrical codes.

302-3 Installation Wiring Connection Diagrams

Please refer to the wiring connection diagram for application being used.

Figure 1 120 VAC Input with External Bypass Switch

Figure 2 208 or 240 VAC Input with External Bypass Switch

Figure 3 208/120 VAC Utility Voltage and External MBB Bypass Switch

Wiring Connection Diagram
120 Volt Input / External Bypass Switch
Figure 1

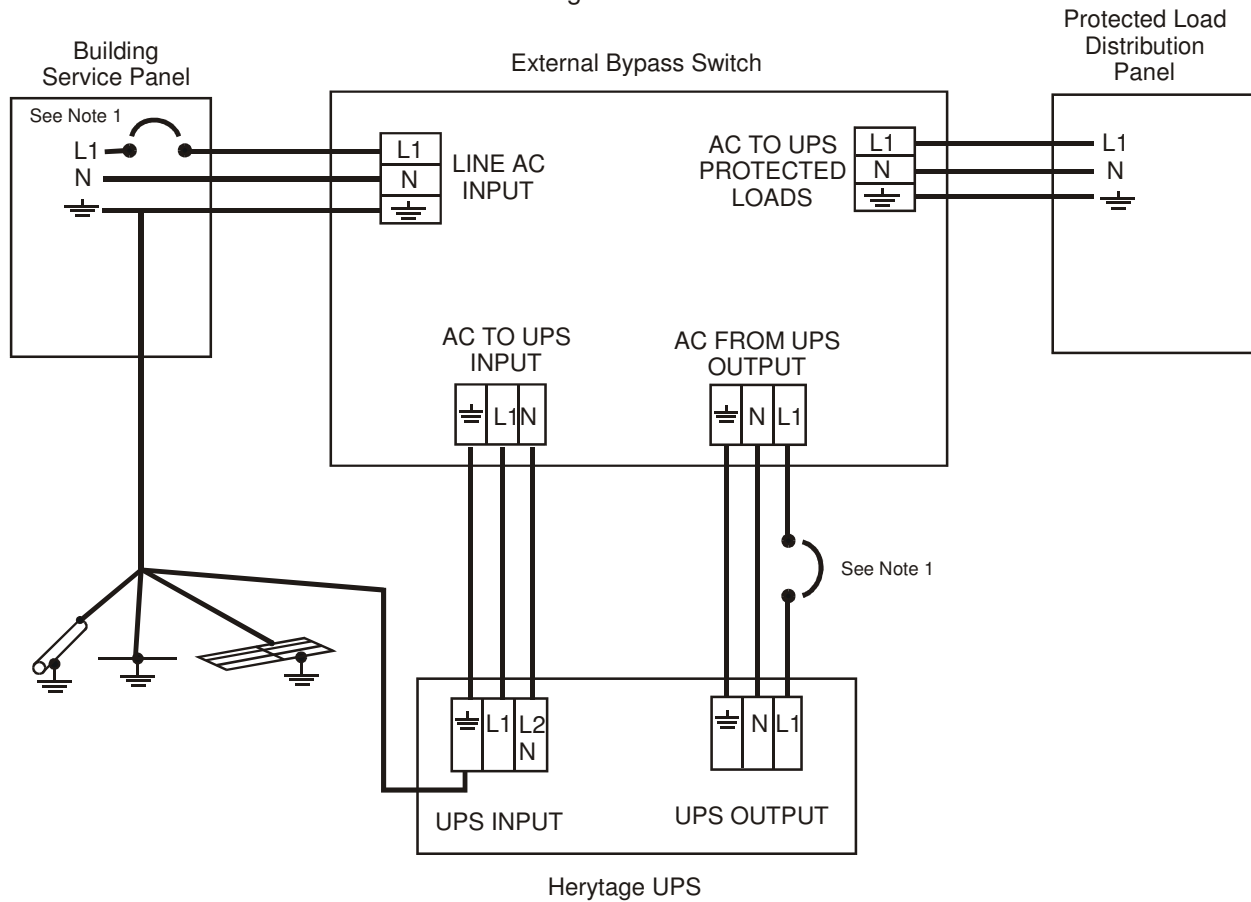

Unit Size	UPS Input Voltage	UPS Output Voltage	Bypass Type
2kVA	120 VAC	120 VAC	BBM or MBB
3kVA	120 VAC	120 VAC	BBM or MBB
4kVA	120 VAC	120 VAC	BBM or MBB
6kVA	120 VAC	120 VAC	BBM or MBB

Note 1: There are no input or output fuses or breakers within the Herytage UPS. Install over-current protection per NEC and Local Codes. See Section 302-3 Table 1 for minimum input over-current protection sizing.

Wiring Connection Diagram
208 or 240 Volt Input / External Bypass Switch
Figure 2

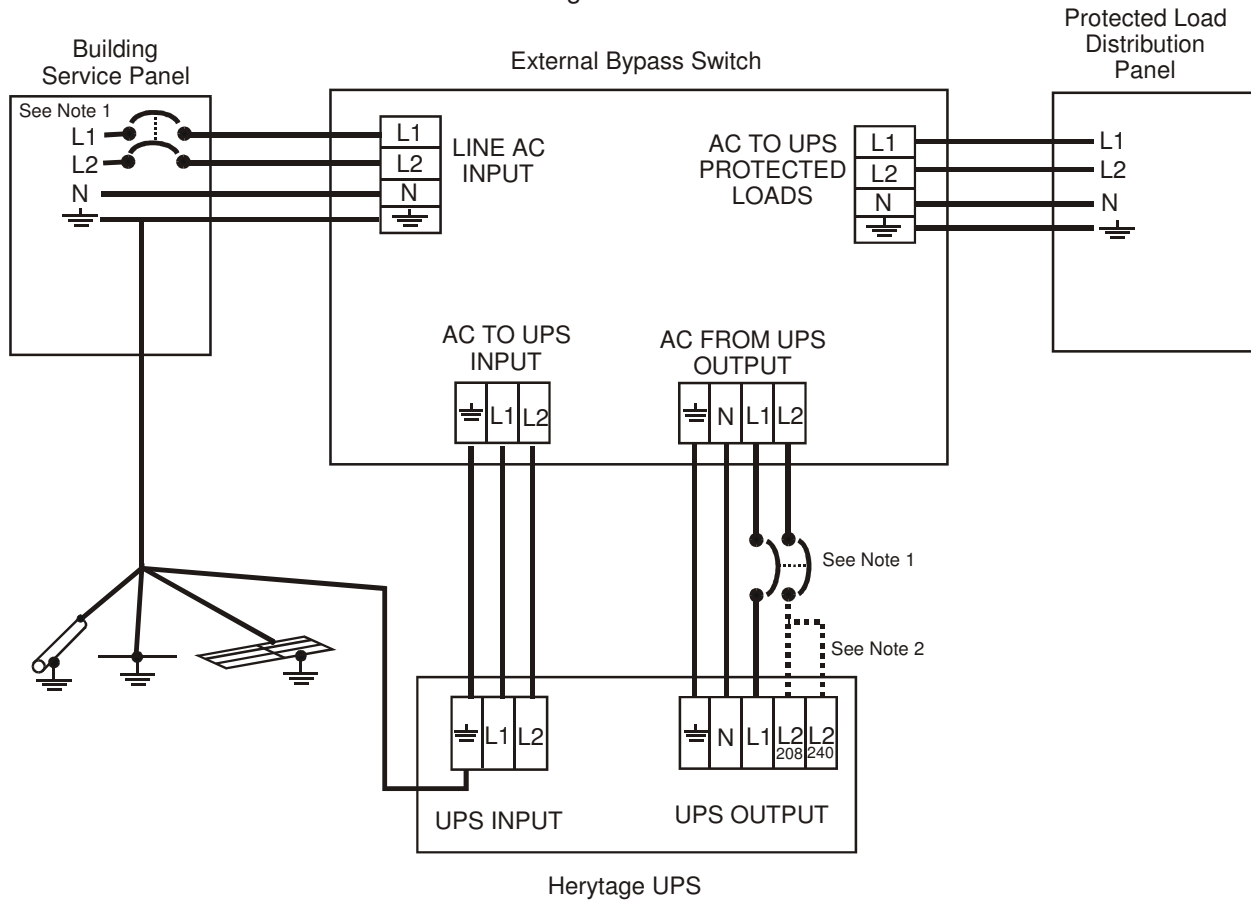

<u>Unit Size</u>	<u>UPS Input Voltage</u>	<u>UPS Output Voltage</u>	<u>Bypass Type</u>
ALL	208 VAC	120/208 VAC	BBM Only
ALL	208 VAC	120/240 VAC	BBM Only
ALL	240 VAC	120/208 VAC	BBM Only
ALL	240VAC	120/240 VAC	BBM or MBB

Note 1: There are no input or output fuses or breakers within the Herytage UPS.
Install over-current protection per NEC and Local Codes.
See Section 302-3 Table 1 for minimum input over-current protection sizing.

Note 2: Connect to terminal L2 / 208 for 208 volt or terminal L@ / 240 for 240 volt.
120 volt loads must be balanced between N to L1 and N to L2 / 240; except on 2 thru 4K product.

<u>Terminals</u>	<u>Voltage Available</u>
N to L1	120 VAC
N to L2 / 240	120 VAC
N to L2 / 208	88 VAC(DO NOT USE)
L1 to L2 / 208	208 VAC
L1 to L2 / 240	240 VAC

Wiring Connection Diagram
208 Volt Input - 240/120 Volt Output/ External MBB Bypass Switch
Figure 3

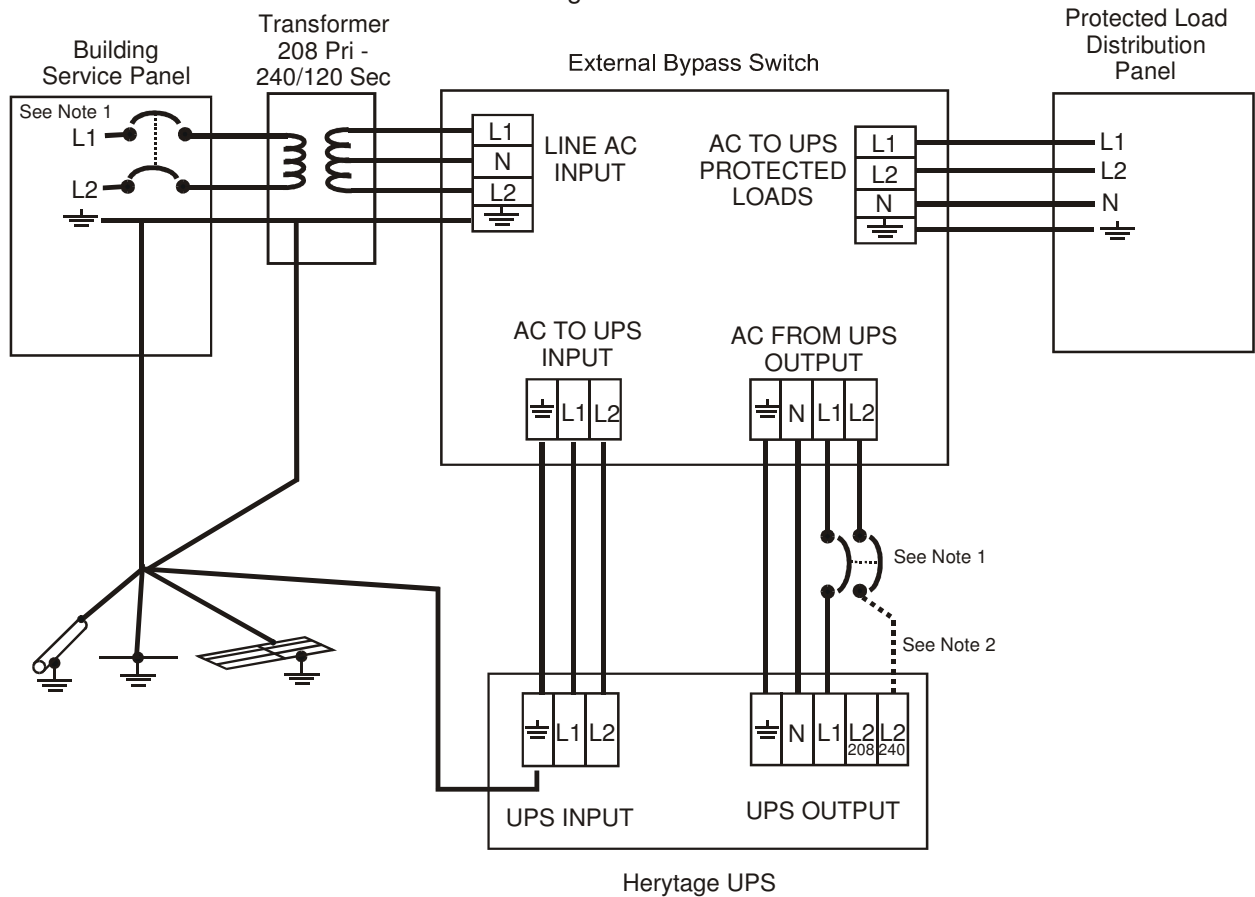

<u>Unit Size</u>	<u>Utility Voltage</u>	<u>UPS Input Voltage</u>	<u>UPS Output Voltage</u>	<u>Bypass Type</u>
ALL	208/120 VAC	240 VAC	120/240 VAC	BBM or MBB

Note 1: There are no input or output fuses or breakers within the Herytage UPS.
 Install over-current protection per NEC and Local Codes.
 See Section 302-3 Table 1 for minimum input over-current protection sizing.

Note 2: Connect to terminal L2 / 240 for 240/120 volt.
 120 volt loads must be balanced between N to L1 and N to L2 / 240; except on 2 thru 4K product..

Terminals	Voltage Available
N to L1	120 VAC
N to L2 / 240	120 VAC
N to L2 / 208	88 VAC (DO NOT USE)
L1 to L2 / 208	208 VAC
L1 to L2 / 240	240 VAC

303 Battery installation and connection

Heritage UPS systems have internal batteries that are already connected or external batteries that must be installed and connected before operation of UPS. To install and connect the batteries in the external cabinet, refer to the Battery Wiring Diagram supplied with the battery cabinet.

The following precautions should be observed when working on batteries:

- Remove watches rings and other metal objects.
- Use tools with insulated handles.
- Wear rubber gloves and boots.
- Do not lay tools or metal parts on top of batteries.

Determine if the battery is inadvertently grounded. If so remove the source of ground. Contact with any part of the grounded battery could result in electrical shock.

Note: Refer to enclosed battery connection diagram for battery connection instructions for UPS utilizing extended runtime batteries (longer than 10 min. at full load).

DANGER: Installation or servicing of batteries should be performed or supervised by personnel knowledgeable of batteries and required precautions. Keep unauthorized personnel away from batteries.

CAUTION: Wear protective clothing and eye wear.

CAUTION: Batteries can present a risk of electrical shock or burn from high short circuit current. Observe proper precautions.

CAUTION: Never open or mutilate batteries. Released electrolyte is harmful to the skin and eyes, and may be extremely toxic.

CAUTION: Battery tray is heavy and can exceed several hundred pounds, insure you are prepared to move such weight.

CAUTION: Disconnect charging source prior to connecting or disconnecting battery terminals.

304 Bypass switch wiring / Phase check (for Hardwired units)

Note: This test is only required if the bypass switch is external to the UPS

After installation of electrical wiring is completed and before operating the bypass switch, it is necessary to insure proper phasing of commercial power feeding the bypass switch with output power from the Herytage UPS.

Bypass switch wiring / phase test

The wiring / phase test should be performed by qualified service personnel or electrician.

1. Insure all load equipment is turned **OFF** and that the main circuit breaker in the load distribution panel feeding the Herytage UPS and your load equipment is **OFF**. The AC disconnect located on the bypass switch, and the bypass switch should also be in the **OFF** position.
2. Remove wiring access panel on bypass switch.
3. Turn **ON** DC breaker located on battery cabinet.
4. Turn **ON AC** breaker in the main service panel feeding the bypass switch.
5. Turn **ON** AC disconnect switch, located on the bypass switch.
6. Turn key-switch to **ON** position; rocker switch on 2 thru 4K products.
7. Turn bypass switch to **UPS** position. Insure the single green LED located on UPS is **ON**, and that the single yellow LED is **OFF**.
8. With an AC volt-meter, measure between the following points on terminal blocks within the bypass switch and record the voltages measured.

Utility Power Terminals

N to L1_____

N to L2_____

L1 to L2_____

Load Terminals

N to L1_____

N to L2_____*

L1 to L2_____

*** If output voltage selected is 120/208 you will measure 88VAC between N and L2 on load terminals, this measurement will not be within 10vac of the same terminals measured on the Utility power terminals – make sure no load equipment is on this output winding.**

Voltages measured on Utility Power terminals should be within ten volts of terminals labeled UPS load. **If not, do not use a Make Before Break bypass switch.** If you need assistance call Legacy Power Conversion customer service for assistance.

- With an AC volt-meter, measure between the following points on the terminal blocks within the bypass switch and record voltages measured.

From	To	Should Measure
Utility Power	Loads	
N	N	< 1vac
L1	L1	< 100vac
L2	L2	< 100vac

If any of the measurements obtained are higher than the “Should measure” column call Legacy Power Conversion customer service for assistance.

- Check voltages within your load distribution panel to insure proper voltages are available for your loads. If not check system for wiring errors or call Legacy Power Conversion customer service for assistance.
- Change bypass switch to the **Line** position and check your load distribution panel to insure proper voltages are present for your loads. If not check system for wiring errors or call Legacy Power Conversion customer service for assistance.
- Turn **OFF** Bypass switch.
- Turn key-switch to **OFF** position; rocker switch on 2 thru 4K units.
- Turn **OFF** AC disconnect switch, located on bypass switch.
- Turn **OFF** DC breaker located on battery cabinet.
- Turn **OFF AC** circuit breaker in main service panel feeding utility power to bypass switch.
- Replace any covers that were removed for wiring / phase test.
- If you are not going to use the Herytage UPS now, but need power to your loads – turn on circuit breaker in the main service panel feeding the bypass switch.
- Turn bypass switch to the **Line** position.
- Turn on your load equipment.

305 User Interface wiring connections

Caution: Before making user interface wiring connections – insure UPS is off, and AC input power and batteries are disconnected.

The UPS has a complete user interface, located on the back panel of the Herytage UPS. The user interface consists of:

Feature	Description
Call in, phone line modem jack (Optional)	Allows you to dial in and diagnose power monitoring history, alarm and inverter logs and parameter settings.
10 pin user connection block	Dual dry contacts for inverter and alarm monitoring, Emergency Power Off, Remote On / Off, 12VDC power supply, AS 400
9 pin RS 232 UPS monitoring and control port	Used for control and monitoring via terminal or computer with terminal emulation software.
RJ – 45 in /out	Network phone line protection

Installation of electrical wiring should be completed by a qualified electrician. National electrical code and applicable local codes should be followed.

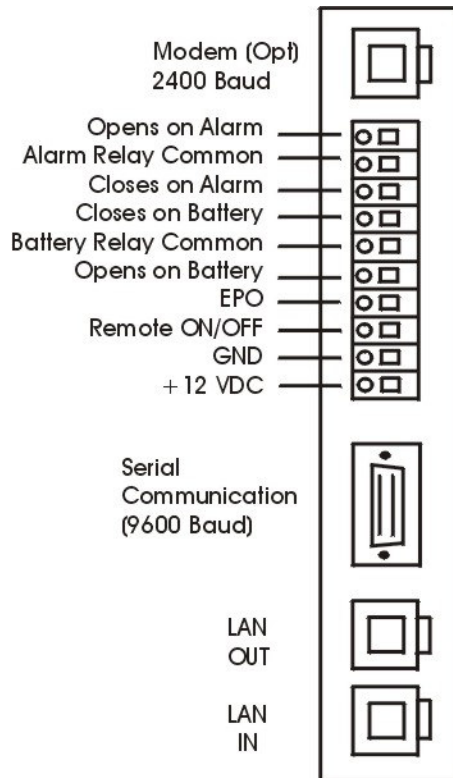

Table 305-1 DB 9 serial communications port pin-outs **

Pin #	Description
1	N/A
2	TD – Transmit data
3	RD – Receive data
4	N/A
5	Signal Ground
6	N/A
7	N/A
8	N/A
9	N/A

** Not to exceed NEC Class 2 wiring methods

Table305- 2 User interface wiring connection block **

Terminal #	Description
1	Alarm on / normally closed contact - 100ma 30Vac / 30Vdc
2	Alarm on / common - 100ma 30Vac / 30Vdc
3	Alarm on / normally open contact - 100ma 30Vac / 30Vdc
4	Inverter on / normally open contact - 100ma 30Vac / 30Vdc
5	Inverter on / common - 100ma 30Vac / 30Vdc
6	Inverter on / normally closed contact - 100ma 30Vac / 30Vdc
7	EPO
8	Remote On / Off
9	Isolated ground / return for pin 1
10	+12 vdc supply / 100ma

** Not to exceed NEC Class 2 wiring methods

EPO – connect terminal #7 to terminal #10 through customer supplied EPO contactor

Remote On / Off - connect terminal #8 to terminal #10 through customer supplied switch

400 System operation

401 Start up

After the Herytage UPS has been completely installed and wired, the system may be started. Follow appropriate start-up instructions listed below.

401-1 Soft-wired units (Line-cord and receptacle)

1. 2-4K units; connect DC connector to battery cabinet and proceed to step 2. If it is a 6-20K unit and has internal batteries, turn on the DC breaker inside the front door of the UPS. If unit has external batteries with a DC breaker / pre-charge as part of system, press pre-charge button for 5 seconds and turn on DC breaker
2. Plug the line cord of the Herytage UPS into wall receptacle.
3. Turn key-switch to **ON** position; rocker switch on 2 thru 4K products.

The green AC line LED should illuminate indicating commercial power is available to the Herytage UPS. If the green LED does not illuminate call Legacy Power Conversion customer service for assistance.

4. Plug your load equipment into the Herytage UPS and turn on your equipment. Note: there may be a breaker switch on UPS supplied receptacles.
5. Program Parameters 23 Date and 24 Time to the correct date and time. If the UPS has external batteries, program Parameter 44 Runtime D to the proper value. Verify that Parameter 34 Charger Mode is programmed to 1 (on).

See section 500 of this manual for more details on lights, keypad, and display functions. If red alarm LED turns on, call Legacy Power Conversion customer service.

Note: For Herytage UPS, full runtime may not be available until batteries have charged for 24 hrs.

401-2 Hardwired units

If after installation, your load equipment was restarted with the bypass switch in **Line** position; turn **OFF** your load equipment and put bypass switch in off position. Also, turn **OFF** breaker in the main service panel feeding bypass switch.

1. If unit has internal batteries, turn on the DC breaker inside the front door of the UPS. If unit has external batteries with a DC breaker / pre-charge as part of system, press pre-charge button for 5 seconds and turn on DC breaker; if it is a 2 thru 4K unit, plug in battery connector.
2. Turn **ON** breaker in the main service panel that feeds bypass switch.
3. Turn **ON** AC disconnect switch – located on bypass switch.
4. Turn key-switch to **ON** position; rocker switch on 2 thru 4K units.

The green AC line LED located on UPS should illuminate indicating commercial power is available to the Herytage UPS. If the green LED does not illuminate, call Legacy Power Conversion customer service for assistance.

5. Plug your load equipment into the Herytage UPS receptacles, if equipped, and turn on your equipment. Note: there may be a breaker switch on UPS supplied receptacles.
6. Program Parameters 23 Date, 24 Time to the correct date and time. If the UPS has external batteries, program Parameter 44 Runtime D to the proper value. Verify that Parameter 34 Charger Mode is programmed to 1 (on).
7. Place bypass switch in **UPS** position.
8. Turn on your equipment.

See section 500 of this manual for more details on lights, keypad, and display functions. If red alarm LED turns on call Legacy Power Conversion customer service.

Note: For the UPS, full runtime may not be available until batteries have charged for 24 hrs.

402 Shutdown of the Herytage UPS

402-1 Soft-wired system (Line cord and receptacles)

1. Turn off load equipment
2. Turn key-switch to **Off** position; rocker switch on 2 thru 4K units.
3. If unit has internal batteries, turn off the DC breaker inside the front door of the UPS. If unit has external batteries with a DC breaker / pre-charge as part of system, turn off the DC breaker; unplug DC connection on 2 thru 4K units.
4. Unplug AC line cord to UPS – if available you can plug loads into commercial power wall receptacles.

402-2 Hardwired systems

402-2-1 With MBB (make before break) Bypass switch

1. Turn bypass switch handle from **UPS** to **Line position**.
2. Turn key-switch on the Herytage UPS **Off**; rocker switch on 2 thru 4K units.
3. If unit has internal batteries, turn off the DC breaker inside the front door of the UPS. If unit has external batteries with a DC breaker / pre-charge as part of system, turn off the DC breaker; unplug DC connection on 2 thru 4K units.
4. Turn **Off** AC disconnect switch located on bypass switch module.

402-2-2 With BBM (break before make) Bypass switch

1. Turn off your load equipment
2. Turn bypass switch handle from **UPS** position to **Line** position.
3. Restart your load equipment.
4. Turn key-switch on the Herytage UPS **Off**; rocker switch on 2 thru 4K units.
5. If unit has internal batteries, turn off the DC breaker inside the front door of the UPS. If unit has external batteries with a DC breaker / pre-charge as part of system, turn off the DC breaker; unplug DC connection on 2 thru 4K units.
6. Turn **Off** AC disconnect switch on bypass switch module.

500 System Features

501 On / Off Switch

A key-switch on the front of the UPS is utilized to turn the Herytage UPS on and off on the 6kVA through 20kVA models. A rocker switch on the rear of the UPS is utilized to turn the Herytage UPS on and off on the 2kVA through 4kVA models

501-1 Herytage UPS On/Off-switch positions

OFF (0) – In this mode there will be no AC power available to your load equipment, the front panel LEDs, keypad, and display will not function.

ON (I) - All AC power to the load equipment will be conditioned, if the input AC power should fail, battery power will turn on and deliver power to load equipment. Once AC power returns, within specifications, battery power will automatically turn off. The front panel LEDs, keypad, and display will function.

502 Bypass switch / AC disconnect operation

There are 2 basic models of bypass / AC disconnect switches available:

- BBM (break before make)
- MBB (make before break)

Both configurations have an **AC disconnect switch** and a **UPS bypass switch**.

502-1 AC disconnect switch

The purpose of the AC disconnect switch is to turn power on and off to the Herytage UPS.

ON - AC power from building service panel will be applied to the Herytage UPS.

OFF - There will be no AC power from building service to the Herytage UPS.

502-2 Bypass switch

The purpose of the Bypass switch is to bypass the Herytage UPS to perform routine maintenance.

OFF - No power from either the building service panel, or from Herytage UPS will be supplied to load equipment.

UPS - If the Herytage UPS is on, conditioned / battery power will be supplied to the load equipment.

Line – If utility power from your building service is available, it will be supplied to load equipment.

502-2-1 BBM (break before make) bypass configurations have an off position in-between the **UPS** position and the **Line** position. When turning the handle through the **OFF** position power will be interrupted to the load equipment.

502-2-2 MBB (make before break) bypass configurations can be switched from the **UPS** position to the **Line** position and vice versa with no loss of power to load equipment if installed correctly. **Note: The UPS must be in the Power Condition mode, or the ON mode with the battery power (yellow) LED OFF.**

503 Display Panel / Front LED lights

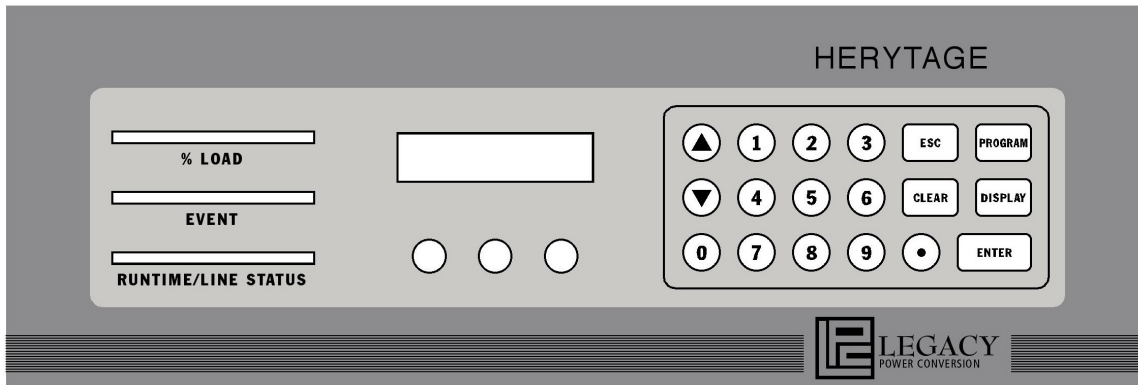

503-1 Bar Graph LEDs

% Load – Displays the percent of full load. Each segment illuminated represents 10% of full load.

Event – Will flash the segments in succession and off again when a power quality event occurs. The event date, start / stop time, and power event type will be recorded in the event log. One single LED segment will illuminate for every 10 events in logs, up until logs are cleared (see parameter #31).

Runtime / Line Status – When single yellow battery operation LED is on Runtime / Line Status 10 LED segment will forecast last remaining 10 minutes of battery operation. Each segment represents approximately 1 minute of runtime remaining.

When green AC line LED illuminates steady and single yellow battery operation LED is off – Runtime / Line Status 10 LED segment will represent nominal AC input voltage by illuminating the center two LED's. For every two volts above or below the nominal voltage, two LED's above or below the center point will illuminate.

503-2 Single LEDs

Green LED – The Green LED will illuminate steady when AC Line is available to the Herytage UPS and AC input power is within nominal range.

The Green LED will flash when AC input power is available, and out of range.

Yellow LED – The yellow LED will illuminate steady when the Herytage UPS is using battery power.

Red LED – The red LED will illuminate steady when there is an alarm condition.

504 Keypad / LCD Display

When the Herytage UPS is on, the LCD display will show the system status and alarm status.

504-1 System Status/System Modes:

OFF- System is turned off via keypad, or shutdown on alarms.

Auto – System is providing conditioned output to the protected loads. UPS will operate on AC line if AC line is within tolerance. If AC line is out of tolerance, UPS will operate on Battery Power.

Line Condition - System is providing conditioned output to the protected loads. UPS will operate on AC line if AC line is within tolerance. If AC line is out of tolerance, UPS will **not** operate on Battery Power. Battery Power is inhibited. Mode must be manually changed via keypad or RS232.

Battery Power – System is providing conditioned output to the protected loads by operating on Battery Power. UPS will **not** operate on AC line even if AC line is within tolerance. AC Line is inhibited. Mode must be manually changed via keypad or RS232.

With the keypad, you can change operating modes, display power quality events, alarm logs, and real time metering levels. It is also possible to program parameters within the system, clear power quality counters, and power quality / alarm logs.

504-2 Passwords

Note: Before changing system operating modes, parameter values or clearing the power quality/ alarm logs, you must first program parameter # 30 (password) with the proper level password. See below on how to program a parameter.

Level 1 = 0877 – allows user to program all level 1 parameters (see parameter table section 605)

Level 2 = For service personnel only – must go through Legacy Power Conversion, Inc. service training course, or work with factory personnel to obtain. If you need assistance call customer service at (800) 859-5711.

504-3 Key Functions

504-3-1 Display

To display a parameter press: *Display, Parameter #*

Note: All parameters can be displayed with no password

504-3-2 Program

To program a parameter press: *Display, Parameter #, Program, New Value, Enter*

504-3-3 UP / Down keys

Once a parameter is displayed, you can use the up/down arrows to scroll through parameter list (see section 605).

504-3-4 Clear

Used to clear or reset parameters, counters, power quality / alarm logs, and to clear alarms.

504-3-5 . (decimal point)

Used to display the power quality / alarm logs – The event log will record: power quality events and alarms. The event log will show the Event #, Event type, Event date, Event time. Must start at the System status mode hit (esc) key. You can scroll through the events by using the UP / Down arrow, the first event shown will be the most recent event.

504-3-6 Escape

Used to back out of the power quality / alarm log mode, programming mode, or display mode (back to system status mode).

505 Parameter Table

Parameter	Sample Value	Password Level	Description
00 System Mode	1	Level 1	<p>Allows the user to change system modes.</p> <p>0=Off Mode – turn system off</p> <p>1=UPS Mode(automatic) – Will condition input power and when needed, turn on battery power</p> <p>2=Line Condition mode – Will condition input power but will not transfer to battery power. Battery power is inhibited.</p> <p>3=Battery Mode – System will only run on battery power.</p> <p>4=Charger Mode – When AC Line is applied to UPS - turns on battery charger There will be no UPS output, but the battery charger will charge the battery. System Mode 4 is valid on 6-20kVA models only.</p>
01 AC Volts In	Actual	Level 2	Displays the measured RMS voltage of input power to the UPS
02 AC Volts Out	Actual	Level 2	Displays the measured output voltage of the UPS. Note: Will display 120 VAC nominal (half of the 120/240 VAC output)
03 AC Amps out	Actual	Level 2	Displays the measured AC output current (amps) of UPS
04 KVA Power out	Calculated	NP*	Displays the calculated kilo-volt amps (kVA) load on output of UPS
05 KW Power out	Actual	Level 2	Displays the measured kilo-watts (kW)of load on output of UPS
06 Percent Load	Calculated	NP*	Displays the calculated percent of load on output of UPS
07 Power Factor	Calculated	NP*	Displays the ratio of watts to volt-amps of load on output of UPS.
08 Spike Volts	Actual	Level 2	Displays the measured peak voltage of input power of UPS
09 AC Frequency	Actual	NP*	Displays the actual frequency of input power of Herytage UPS
10 Future Use		NP*	
11 Future Use		NP*	
12 Future Use		NP*	
13 Future Use		NP*	
14 Future Use		NP*	
15 Vin minimum		Level 1	<p>Displays the lowest RMS voltage measured on input power to UPS since last reset</p> <p>– to reset, install password, display parameter, and press clear</p>
16 Vin maximum		Level 1	<p>Displays the Highest RMS voltage measured on input power to UPS since last reset.</p> <p>– to reset, install password, display parameter, and press clear</p>

Parameter	Sample Value	Password Level	Description
17 Vin spike max		Level 1	Displays the Highest peak voltage spike measured on the input power to the UPS since last reset. – to reset, install password, display parameter, and press clear
18 Vin Nom Set	120 208 240	Level 2	Nominal input voltage
19 Vin High Set	120=138 208=240 240=275	Level 2	Input RMS voltage that causes UPS to go to battery power ; also recorded as a surge in parameter #11
20 Vin Spike Set	120=300 208=500 240=500	Level 1	Input peak voltage that will record as a spike in parameter # 13
21 Vout Low Set	110	Level 2	Set-point at which low AC output alarm occurs – UPS will shut down if this set-point is exceeded
22 Vout High Set	130	Level 2	Set-point at which high AC output alarm occurs – UPS will shut down if this set-point is exceeded
23 Date	09/21/07	Level 1	Current Date (Month / Day / Year)
24 Time	14:43	Level 1	Current Time (24 hour format)
25 Alarm Mask 1	192	Level 1	Allows you to program which alarms activate the dry contact for remote signaling, sound beeper and alarm light
26 Alarm Mask 2	255	Level 1	Allows you to program which alarms activate the dry contact for remote signaling, sound beeper and alarm light.
27 Alarm Mask 3	110	Level 1	Allows you to program which alarms activate the dry contact for remote signaling, sound beeper and alarm light
28 Model		Level 2	Tells microprocessor what size UPS system to be.
29 Auto Restart	0,1	Level 1	Determines if the Herytage UPS will automatically restart after a low battery condition when AC line returns, or if the system will start when the key / switch is turned on – if set to no, you must start the Herytage by programming parameter Number 00 System Mode 0=No, 1=Yes
30 Password	0000, 0001	none	Password Level 0 = All parameters are display only Password Level 1= Parameters noted as Password Level 1 can be programmed. To change to level 1 program parameter 30 to 0877. Parameter 30 will then show 30 Password 0001. To remove or reset password press program then enter (0000) with parameter #30 displayed
31 Clear logs		Level 1	Press clear with this parameter displayed to clear event logs – level 1 password must be entered in parameter # 30 first
32 Software Ver	H15	NP*	Displays the software version installed within the control board
33 Batt.Volts	091.7	Level 2	Actual measured voltage of the Herytage UPS batteries.
34 Charger Mode	0 or 1	Level 1	Allows the user to change charger modes. 0= Off 1= On

Parameter	Sample Value	Password Level	Description
35 Charger Amps	06.7	Level 2	Actual measured battery charger output current of Herytage UPS battery charger.
36 Inverter Amps	000	Level 2	Actual measured battery current when running on battery power.
37 Sensitivity	25	Level 2	Determines the sensitivity of the Herytage UPS.
38 Glitch Count	1 to 5	Level 2	Determines the sensitivity of the Herytage UPS.
39 GFE	NA	Level 2	only used in calibration process – by factory trained personnel.
40 Shutdn Inhib	0,1	Level 2	only used in calibration process – by factory trained personnel.
41 Runtime a	3.7	NP*	Variable used In calculation of Runtime – Do Not Change
42 Runtime b	1931	NP*	Variable used In calculation of Runtime – Do Not Change
43 Runtime c	42922	NP*	Variable used In calculation of Runtime – Do Not Change
44 Runtime d		Level 2	Variable used In calculation of Runtime to indicate AH rating of total battery pack. The formula is based on the number of 33 amp hour strings times the number of cells in one string. The factory default for standard batteries should be: 2k = 13, 3k and 4k = 24, 6k = 36, 8k = 48, 10k = 60, 16k = 109, 20k = 136. For other battery configurations calculate the setting as: 2, 3, 4k = 24 x (total Amp Hours / 33) 6k = 36 x (total Amp Hours / 33) 8k = 48 x (total Amp Hours / 33) 10k = 60 x (total Amp Hours / 33) 16k = 48 x (total Amp Hours / 33) 20k = 60 x (total Amp Hours / 33)
45 Runtime e	80	NP*	Variable used In calculation of Runtime – Do Not Change
46 Runtime	Varies	NP*	Displays battery time remaining – only when on battery power
47 CF-Vin-M	Varies	Level 2	Calibration Factor for AC Volts In. Value varies with unit
48 CF-Vin-L	Varies	Level 2	Calibration Factor for AC Volts In. Value varies with unit
49 CF-Vout-M	Varies	Level 2	Calibration Factor for AC Volts Out. Value varies with unit
50 CF-Vout-L	Varies	Level 2	Calibration Factor for AC Volts Out. Value varies with unit
51 CF-Aout-M	Varies	Level 2	Calibration Factor for AC Amps Out. Value varies with unit
52 CF-Aout-L	Varies	Level 2	Calibration Factor for AC Amps Out. Value varies with unit
53 CF-DCV-M	Varies	Level 2	Calibration Factor for DC Volts. Value varies with unit
54 CF-DCV-L	Varies	Level 2	Calibration Factor for DC Volts. Value varies with unit
55 CF-Ainv-M	Varies	Level 2	Calibration Factor for DC Amps on Inverter. Value varies with unit

Parameter	Sample Value	Password Level	Description
56 CF-Ainv-L	Varies	Level 2	Calibration Factor for DC Amps on Inverter. Value varies with unit
57 CF-Achgr-M	Varies	Level 2	Calibration Factor for Charger DC Amps. Value varies with unit
58 CF-Achgr-L	Varies	Level 2	Calibration Factor for Charger DC Amps. Value varies with unit
59 CF-ACpk-M	Varies	Level 2	Calibration Factor for Spike Volts. Value varies with unit
60 CF-ACpk-L	Varies	Level 2	Calibration Factor for Spike Volts. Value varies with unit
61 CF-Watts-M	Varies	Level 2	Calibration Factor for Watts. Value varies with unit
62 CF-Watts-L	Varies	Level 2	Calibration Factor for Watts. Value varies with unit
63 Future Use		NP*	
64 Future Use		NP*	
65 ITest	30	No Password Required	Number of days between inverter test – program to same value or a different value to manually start test. The test result, time, and date of the inverter test will be posted in the event log.
66 Low Batt	10.0	Level 2	Low battery shutdown voltage – See section 700 for an alarm description. Low Battery Alarm setpoint. Value is programmed per battery. Typical value is 010.0
67 Nom Batts		Level 2	Number of 12vdc batteries in one string – used to determine high battery, low battery, and charger setpoints
68 Inverter Mins		Level 1	Number of minutes UPS has ran on battery power – to reset press clear button when parameter is displayed
69 Inverter Runs		Level 1	Number of times Inverter has turned on – to reset press clear button when parameter is displayed
70 Chgr On V	13.0	Level 2	Voltage per battery that the battery charger turns on
71 Chgr Off V	14.0	Level 2	Voltage per battery that the battery charger turns off
72 Batt Fail V	6	Level 2	Voltage per battery that causes the Battery Fail Alarm
73 Xfr Inhibit Ult	012.8	Level 2	Specialty Customer Application Only
74 Future Use		NP*	
75 Alm Rly Mask1	192	Level 1	Disables or enables certain alarm from engaging dry contacts. Alarms will still be entered into events log. See Section 703.
76 Alm Rly Mask2	255	Level 1	Disables or enables certain alarm from engaging dry contacts. Alarms will still be entered into events log. See Section 703.
77 Alm Rly Mask3	110	Level 1	Disables or enables certain alarm from engaging dry contacts. Alarms will still be entered into events log. See Section 703.
78 HiBat SD Time	000	Level 1	Delay time before shutdown due to High Battery Alarm.
79 DCV Maximum	112.0	Level 1	Highest recorded DC voltage since last reset – to reset, install password, display parameter, and press clear
80 Near Low Batt	11.0	Level 2	Near Low Battery Alarm setpoint. Value is programmed per battery. Default is 011.0
81 Brnout 0-50%	60	Level 1	Percent of nominal input voltage (parameter 18) at which the UPS will go to inverter based on load percent of 0 – 50%.

Parameter	Sample Value	Password Level	Description
82 Brnout 51-75%	70	Level 1	Percent of nominal input voltage (parameter 18) at which the UPS will go to inverter based on load percent of 51 – 75%.
83 Brnout >76%	80	Level 1	Percent of nominal input voltage (parameter 18) at which the UPS will go to inverter based on load percent greater than 76%.

NP* = Not Programmable

600 RS 232 Serial Communications

You can display power quality logs, parameters, alarm logs, and real time metering levels of the Herytage UPS through the DB – 9 serial communications port or call in modem. You can also program parameters, clear system counters and change system modes.

601 DB – 9 Serial communications terminal / computer hook up

1. Utilize a standard 9 pin male to 9 pin female shielded data communications cable.
2. Plug cable into 9 pin RS 232 serial communications port located on rear side of UPS (see user connection section 305) and serial communications port of the terminal or computer.
3. Set terminal or terminal emulation software to:
 - ANSI terminal
 - 9600 baud
 - 8 data bits, 1 stop bit
 - No Parity
 - Full Duplex

The terminal will display system mode and alarm status once communications are established.

602 System Status/System Mode

OFF- System is turned off via keypad, or shutdown on alarms.

Auto – System is providing conditioned output to the protected loads. UPS will operate on AC line if AC line is within tolerance. If AC line is out of tolerance, UPS will operate on Battery Power.

Line Condition - System is providing conditioned output to the protected loads. UPS will operate on AC line if AC line is within tolerance. If AC line is out of tolerance, UPS will **not** operate on Battery Power. Battery Power is inhibited. Mode must be manually changed via keypad or RS232.

Battery Power – System is providing conditioned output to the protected loads by operating on Battery Power. UPS will **not** operate on AC line even if AC line is within tolerance. AC Line is inhibited. Mode must be manually changed via keypad or RS232.

603 Passwords

Note: Before programming or clearing the power quality logs you must first program parameter # 30 (password) with the proper level password for the parameter you are programming.

Level 1 Password = 0877

Level 2 password = For service personnel only – must go through Legacy Power Conversion, Inc. service training course, or work with factory personnel to obtain. If you need assistance call customer service at (800) 859-5711.

604 RS232 Commands

D To display a parameter press: *D, Parameter #*

Note: All parameters can be displayed with no password

P To program a parameter press: *D, parameter #, P, New Value, Enter*

UP / Down keys: Once a parameter is displayed you can use the up/down arrows to scroll through the parameter list.

C Used to clear or reset parameters, counters, power quality / alarm logs, and to clear alarms.

L Used to display Power quality / Alarm logs – This event log will record: power quality events and alarms. The event log will show the Event #, Event type, Event date, Event time. You can scroll through the events by using the UP / Down arrow. First event shown will be most recent event. Must use (ESC) key to back out to the System Status mode.

Escape Used to back out of the log mode, program mode, or display mode.

Control D This keyboard command will send complete parameter list out of RS-232 port

Control L This keyboard command will send complete log list out of RS-232 port

605 Modem hook up (Optional)

1. Plug a phone line into the modem jack. (see user connections, section 305)
Note: Do not use a phone line that originates from a PBX.
2. To call the Herytage UPS utilize a computer fitted with a modem and modem / terminal emulation software.
3. Set terminal emulation parameters to:
 - ANSI terminal
 - 9600 baud
 - 8 data bits, 1 stop bit
 - No Parity
 - Full Duplex

Call Herytage UPS, once connected, computer will display system mode and alarm status.

700 Alarms

Listed below is a table that describes alarms Herytage UPS could have, conditions required to activate the alarm, and response Herytage UPS will have because of alarm conditions (shutdown, alarm latch).

701 Shutdown and Latching Alarms

If an alarm causes the Herytage UPS to shut down or an alarm latches on, condition that caused alarm must be corrected, and unit must be reset by pressing clear button. **Before pressing clear insure LCD display is in system status scrolling mode – if a parameter is presently displayed press escape a couple of times to get to system status scrolling mode (Note: The only exception to this is low battery alarm. If auto restart parameter is set to “yes” UPS will automatically restart when AC input power has returned and is within acceptable limits and alarm will clear automatically).**

If condition that caused the alarm cannot be located and corrected – Turn Herytage UPS off and bypass system. Call Legacy Power Conversion, Inc. customer service department @ 800 859-5711.

702 Alarm Table

Alarm	Description	Shut-down	Latching
Thermo Error	An over-temperature condition exists in the inverter module, the system will shutdown in 2 seconds.	Yes	Yes
Output overload	In UPS mode / on AC line, line condition, or as a line conditioner system will alarm at 101% to 125% load for 10 min. before it will shutdown. Over 125% load system will shutdown in 5 seconds. In UPS mode / on battery , the system will alarm at 101% to 110% load for 10 min. before it will shutdown. Over 110% load, system will shutdown in 5 seconds.	Yes	Yes
Memory error	Each time system is turned on it performs a check of information stored in memory. If any problems are found system will sound a memory error alarm.	Yes	Yes
Emergency Power Off (EPO)	Indicates EPO (emergency power off) option has been activated.	Yes	Yes
Near Low Battery	Indicates system has been running on battery long enough to reach the near low battery voltage setting, if same AC input voltage continues UPS will shut off on Low Battery alarm soon. This is a normal alarm if there is an extended power outage. This is programmed to 10% above low battery from the factory.	No	No

Alarm	Description	Shut-down	Latching
Low Battery	<p>Indicates low battery voltage level has been reached. This is normal alarm if an extended power outage occurs. This alarm may also occur if the battery charger has been disabled. Verify Parameter 34 Charger Mode is set to 1.</p> <p>If parameter # 29 is set to auto restart “yes” system will automatically restart when power returns, and is within acceptable limits. Factory settings are: 40 VDC for 2kVA, 3kVA, and 4kVA Systems 60VDC for 6kVA Systems 80VDC for 8kVA and 16kVA Systems 100VDC for 10kVA and 20kVA Systems</p>	Yes	No
High Battery	<p>Indicates the high battery voltage setting has been reached. Factory settings are: 59 VDC for 2kVA, 3kVA, and 4kVA Systems 89VDC for 6kVA Systems 118VDC for 8kVA and 16kVA Systems 147VDC for 10kVA and 20kVA Systems</p>	No	Yes
Charger Fail	<p>Indicates charger has failed, this alarm causes charger mode (parameter #34) to change to OFF (value 0) – after the charger has been repaired this parameter must be changed to a value of 1 to reactivate the charger.</p>	No	Yes
High AC output	<p>Indicates output voltage of Herytage power conditioner / UPS has gone above V out High set-point, parameter # 22 .</p>	Yes	Yes
Low AC output	<p>Indicates output voltage of Herytage power conditioner / UPS has gone below V out low set-point, parameter # 21 .</p>	Yes	Yes
Surge Fault	<p>Indicates input surge protection fuse (s) have opened .</p>	No	Yes
Fan Failure	<p>Indicates transformer or SCR Heat-sink assembly have overheated, system will shutdown in 10min. – usually caused by fan failure .</p>	Yes	Yes
Output Error	<p>Indicates output voltage has exceeded the output window values of parameter #21 V out low set and Parameter #22 V out high set for more than 5 seconds</p>	Yes	Yes
Battery Fail Alarm	<p>Indicates battery voltage has dropped below parameter #72 Batt Fail V set-point – note this alarm causes charger mode (parameter #34) to change to OFF (value 0) – after this alarm is cleared parameter #34 must be changed to a value of 1 to reactivate the charger. Verify that the UPS or battery cabinet DC breaker or switch is on.</p>	No	No
Inverter Fail	<p>Indicates Inverter self test has failed. This alarm causes the system mode (parameter #00) to change to the Line Condition mode (value 2) Note: battery back-up power (Inverter) cannot turn on in this mode.</p>	No	Yes

703 Alarm Mask

Parameters 25, 26 and 27 allow you to specify which alarm conditions will activate the audio beeper, illuminate the red alarm led on the keypad, and change the state of the dry alarm contacts. Note: The event log will still record all alarms regardless of the alarm mask setting. Parameters 75, 76, and 77 only change the state of the dry alarm contacts.

To enable alarms, add the numbers assigned to the specific alarms that you wish to enable. Program the total value into the appropriate alarm mask parameter.

Parameter #	Factory Value
25/75 Alarm Mask 1	192
26/76 Alarm Mask 2	255
27/77 Alarm Mask 3	110

P25/75 Alarm Mask 1	Alarm Value	Factory Enabled (192)
Null	Null	
Vin Low V	Add 2	
Vin High V	Add 4	
Vin High Spike	Add 8	
Vin Freq Error	Add 16	
Vin Glitch Detect	Add 32	
Vout Error	Add 64	X
Remote Off	Add 128	X

P26/76 Alarm Mask 2	Alarm Value	Factory Enabled (255)
Output Overload	Add 1	X
Thermo	Add 2	X
Memory Error	Add 4	X
Emergency Power Off	Add 8	X
Near Low Battery	Add 16	X
Low Battery	Add 32	X
High Battery	Add 64	X
Charger Failure	Add 128	X

P27/77 Alarm Mask 3	Alarm Value	Factory Enabled (110)
Inverter Test Pass	Add 1	
Inverter Test Fail	Add 2	X
Battery Fail	Add 4	
DC Power Up	Add 8	X
Phase Lock	Add 16	
Surge Fault	Add 32	X
Fan Failure	Add 64	X
Null	Add 128	

800 Battery removal / replacement

Servicing of batteries should be performed or supervised by personnel knowledgeable of batteries and required precautions. Keep unauthorized personnel away from batteries.

When replacing batteries in the UPS, replace with the same number and type of battery originally supplied in the UPS.

Energys NP18-12BFR (Legacy Part Number BAT-0373)
C&D Technologies UPS12-140 (Legacy Part Number BBAT-0065)
Energys NP33-12 (Legacy part number BBAT-0065)
C&D Technologies UPS12-150MR (Legacy Part Number BBAT-10031)
Panasonic LC-LA1233P
Power Battery TC-1235L or PRC-1235L

When replacing batteries in the battery cabinet, replace with the same number and type of battery originally supplied in the battery cabinet.

Energys NP18-12BFR (Legacy Part Number BAT-0373)
C& D Technologies UPS12-140 (Legacy Part number BBAT-0065)
C&D Technologies UPS12-150MR (Legacy Part Number BBAT-10031)
Energys NP33-12 (Legacy part number BBAT-0065)
C&D Technologies UPS12-270 (Legacy Part number BBAT-0103)
C&D Technologies UPS12-300MR (Legacy Part Number BBAT-10032)
C&D Technologies UPS12-310 (Legacy Part number BBAT-0122)
C&D Technologies UPS12-350MR (Legacy Part Number BBAT-10033)

801 Battery safety / cautions

Important Safety instructions – save these instructions

CAUTION: Wear protective clothing and eye wear.

CAUTION: Batteries can present a risk of electrical shock or burn from high short circuit current. Observe proper precautions.

CAUTION: Proper disposal of batteries is required. Refer to your local codes for disposal requirements.

CAUTION: Never dispose of batteries in a fire. The batteries may explode.

CAUTION: Never open or mutilate batteries. Released electrolyte is harmful to the skin and eyes, and may be extremely toxic.

The following precautions should be observed when working on batteries:

- Remove watches rings and other metal objects.
- Use tools with insulated handles.
- Wear rubber gloves and boots.
- Do not lay tools or metal parts on top of batteries.
- Determine if the battery is inadvertently grounded. If so remove the source of ground. Contact with any part of the grounded battery could result in electrical shock.

Heritage Limited Warranty

Legacy Power Conversion, Inc. (hereinafter called "seller") warrants each product sold by it to be free from defects in material and workmanship under normal use and service beginning with the date of delivery subject to the following conditions: The warranty period is classified as Three (3) years Limited Warranty plus seven (7) years pro-rated and is limited to the replacement or repair, during the warranty period and subject to conditions enumerated below, of such product returned intact which shall appear to Seller upon inspection, to have been defective in material or workmanship. Replacement or repair will be accomplished at Legacy Power Conversion, Inc. Customer Service Department, Suite 7, N9246 Hwy 80 South, Necedah, WI. Such replacement shall be made free of charge if a defect becomes apparent and Seller is notified within the warranty period.

This warranty does not include any taxes which may be due in connection with replacement or repair, nor any installation, transportation, or postage costs. No warranty is made with respect to other products sold by Seller which do not bear the name Legacy Power Conversion, Inc. and no recommendation of such other products shall imply or constitute any warranty with respect to them. This warranty does not cover repair or replacement because of damage from unreasonable use (damage from road hazards, accident, fire or other casualty, misuse, negligence, incorrect wiring) and any use or installation not in conformance with instructions furnished by Seller or repairs or replacement needed because of modification or parts not authorized or supplied by Seller. This warranty is expressly in lieu of any other warranties, express or implied including any warranty of merchantability or fitness for particular purpose. Remedies under this warranty are expressly limited to the provision of products as specified above and any claims for loss arising out of the failure of products to perform for any period of time, or special, indirect or consequential damages or other economic loss expressly excluded.

This Page Intentionally Left Blank

Warranty Registration Form
Fax or mail this form to activate your warranty

Serial Number _____

Installation Date _____
Month / Date / Year

Contact Person _____

Company _____

Street Address _____

City _____

State _____

Zip Code _____

Phone Number _____
Ext.

Type of Business _____

Load Equipment _____

<i>Manufacturer</i>	<i>Model</i>	<i>Voltage</i>	<i>VA</i>
---------------------	--------------	----------------	-----------

Fax to: **(608) 565-5879**

Fold in half and tape – DO NOT STAPLE

Place Stamp
Here

Legacy Power Conversion, Inc.
Suite 7
N9246 Hwy 80 South
Necedah, WI 54646